



## RKL 160

Rotary vane compressor

**CVS develops and manufactures compressors specifically designed for installation in trucks. The development is made in close collaboration with our customers. This guarantees the optimum product for your application.**



### The oil free rotary vane compressor

The oil free compressor RKL was developed especially for the high requirements on mounting in liquid tankers.

### Features

- » High quality compressors from CVS for reliable discharge
- » Durable and robust design guarantee long lasting performance and high operating hours
- » Compact and light-weight compressors for higher payload on the tanker

### Compressors with system

The compressor RKL delivers a volume flow between 116 up to 154 m<sup>3</sup>/h / 92 - 123 cfm. An efficient cooling system of the RKL 160 ensures improved service life.

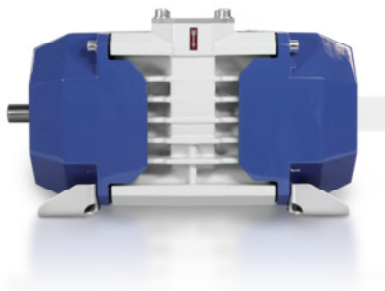

### Advantages

- » Variable mounting brackets
- » Optimized cooling
- » Clockwise or counter-clockwise rotation
- » Low weight
- » Compact design
- » Variable position from suction and pressure flange
- » Drive via hydraulic motor or directly via cardan shaft possible
- » Permanent lubrication for bearings
- » 2.5 bar g (35.5 psig) operating pressure for the complete speed range possible
- » Fan and fan cover made of aluminium

### Dimensions

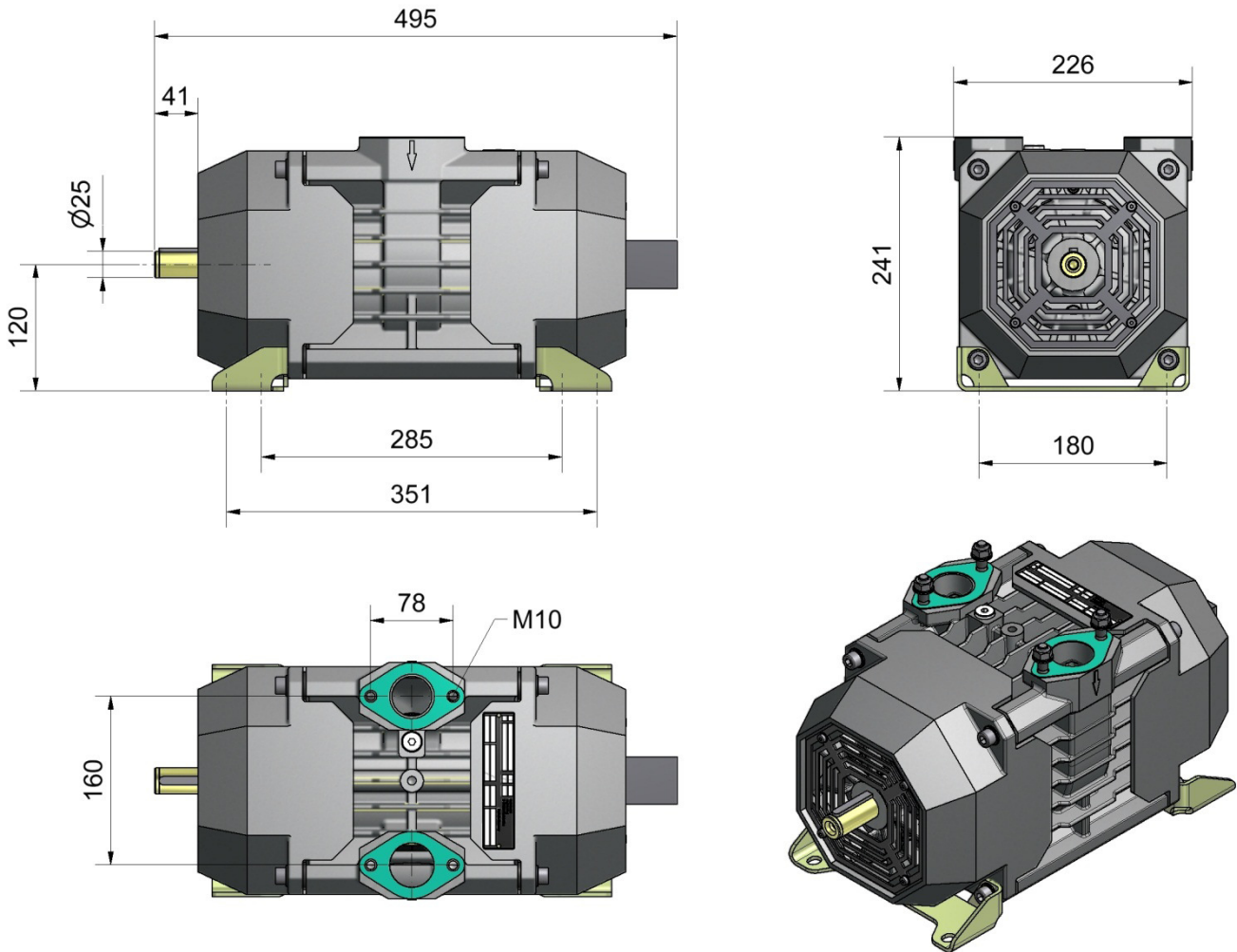

### Technical data

		RKL 160
Volume flow at free air	m <sup>3</sup> /h / cfm	116 - 154 / 68 - 91
Volume flow at 2 bar g / 28.4 psig	m <sup>3</sup> /h / cfm	92 - 123 / 54 - 72
Max. operating pressure	bar / psig	2.5 / 35.5
Speed	1/min / rpm	1200 - 1600
Power requirement at 2.5 bar g / 28.4 psig	kW / hp	6.5 – 8.6 / 11.7 – 16.9
Weight	kg / lb	33 / 73

Technical subject to alteration