

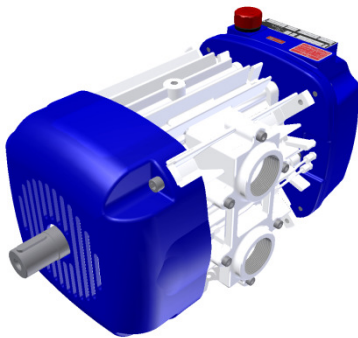

VacuStar L 400

Compressor

CVS develops and manufactures compressor vacuum-pumps and compressors specifically designed for installation in vacuum trucks. The development is made in close collaboration with our customers. This guarantees the optimum product for your application.



The compressor

The air cooled series L was developed especially for the high requirements for unloading suction vehicles.

Features

- » High quality compressors from CVS for reliable discharge
- » Durable and robust design guarantee long lasting performance and high operating hours
- » Compact and light-weight compressors for higher payload on the truck

Compressors with system

The series L delivers a volume flow from 225 up to 345 m³/h / 130 - 203 cfm. The compressor is lubricated automatically by an integrated oil pump.

Advantages

- » Connectivity for hydraulic motor
- » Optimized cooling
- » Low weight
- » Visual oil level indicator
- » Shaft end exposed for driving using V-belts, cardan shaft and flexible coupling

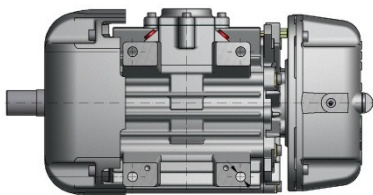

www.boogertbv.nl

Dimensions

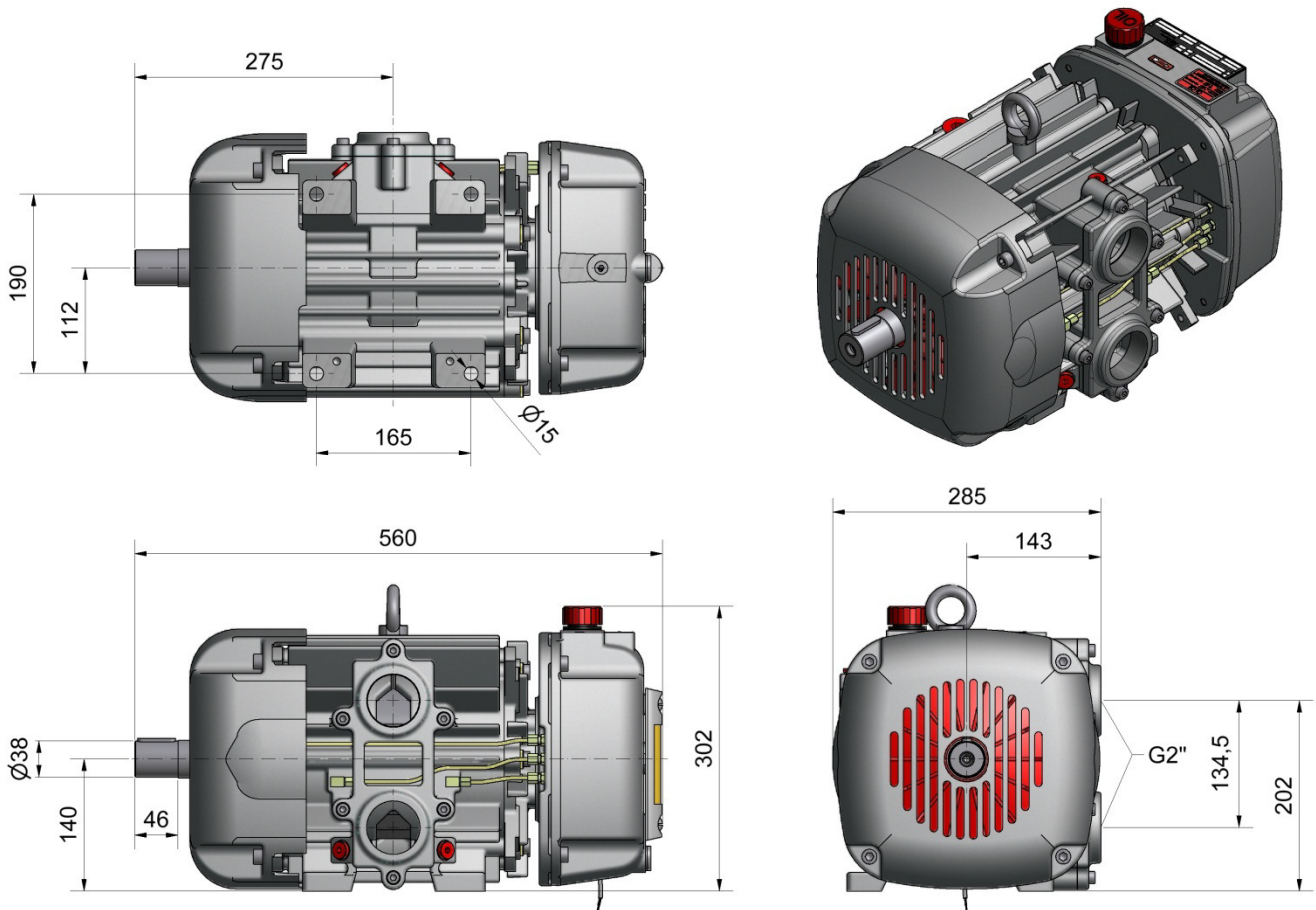

Technical data

		VacuStar L 400
Volume flow at free air	m³/h / cfm	225 - 345 / 130 - 203
Volume flow at 2 bar g / 29 psig	m³/h / cfm	190 - 305 / 110 - 179
Max. operating pressure	bar g / psig	2.0 / 29.0
Speed	1/min / rpm	1000 - 1500
Power requirement at 2 bar / 29 psi	kW / hp	12.5 - 19 / 17 - 25.5
Sound pressure level in 7 m distance, at 2 bar g / 29 psig	dB(A)	75 - 77
Weight incl. mounting flange for suction and pressure pipe	kg / lb	79 / 174

Technical subject to alteration