



## SKL / SKL LS

Screw compressor with gear box

CVS develops and manufactures compressors specifically designed for installation in trucks. The development is made in close collaboration with our customers. This guarantees the optimum product for your application.



### The oil free screw compressor

The oil free screw compressor SKL with gear box was developed especially for the high requirements on mounting in bulk trucks.

### Features

- » High quality screw compressors from CVS for reliable discharge
- » Unique and robust design guarantee long lasting performance and high operating hours
- » Compact and light-weight compressors for higher payload on the tanker

### Screw compressors with system

The volume flow range of the compressor SKL with gear box goes from 385 up to 1050 m<sup>3</sup>/h at different drive speed ranges (look at technical data). The newly developed design of screw ensures an increased degree in efficiency, low compressed-air discharge temperature and a quiet operation.



### Advantages

- » 2 additional gear boxes with  $i = 1:2$  and  $i = 1:2.5$  available
- » Gear box for clockwise and counter-clockwise drive possible
- » Wide drive speed range
- » Drive shaft can be mounted at the top or at the side

## Dimensions

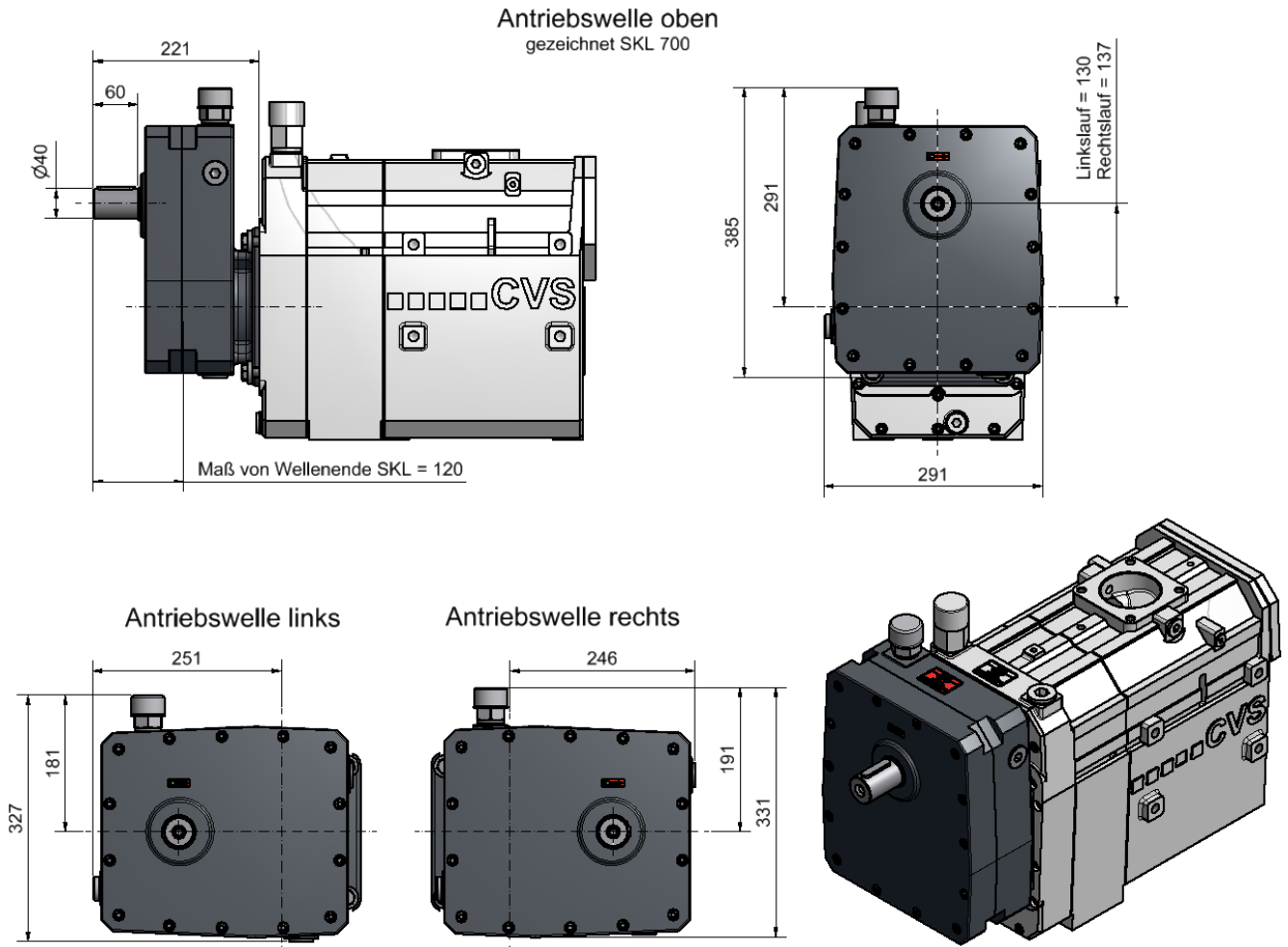

## Technical data

		SKL 700 / SKL 700 LS		SKL 1100 / SKL 1100 LS	
<b>Volume flow at free air</b>	<b>m<sup>3</sup>/h</b>	420	650	550	1050
<b>Volume flow at 2 bar g</b>	<b>m<sup>3</sup>/h</b>	385	600	490	980
<b>Max. pressure</b>	<b>bar</b>	2.5	2.5	2.5	2.5
<b>Speed range:</b>					
<b>with gear box 1:2</b>	<b>1/min</b>	1200 – 1800 / 900 – 1350		1000 – 1800 / 750 – 1350	
<b>with gear box 1:2,5</b>		960 – 1440 / 720 – 1080		800 – 1440 / 600 – 1080	
<b>Power requirement at 2 bar</b>	<b>kW</b>	22.5	33.5	29.0	52.5
<b>Weight</b>	<b>kg</b>	152 / 159		165 / 172	

Technical subject to alteration