



SKL

Screw compressor

CVS develops and manufactures compressors specifically designed for installation in trucks. The development is made in close collaboration with our customers. This guarantees the optimum product for your application.

The oil free screw compressor

The oil free screw compressor SKL was developed especially for the high requirements on mounting in bulk trucks.



Features

- » High quality screw compressors from CVS for reliable discharge
- » Unique and robust design guarantee long lasting performance and high operating hours
- » Compact and light-weight compressors for higher payload on the tanker

Screw compressors with system

The volume flow range of the compressor SKL goes from 385 up to 1050 m³/h at a drive speed of 2000 (SKL 1100) resp. 2400 (SKL 700) up to 3600 rpm. The newly developed design of screw ensures an increased degree in efficiency, low compressed-air discharge temperature and a quiet operation.



Advantages

- » High availability through robust and qualitative high quality design
- » Low weight
- » Optimum adjustment of the volume flow by the use of the large speed range
- » 2.5 bar operating pressure arranged over the full speed range
- » Compact dimensions for easier installation
- » Integrated oil pump for the gearbox and easy-to-change oil filter

Dimensions

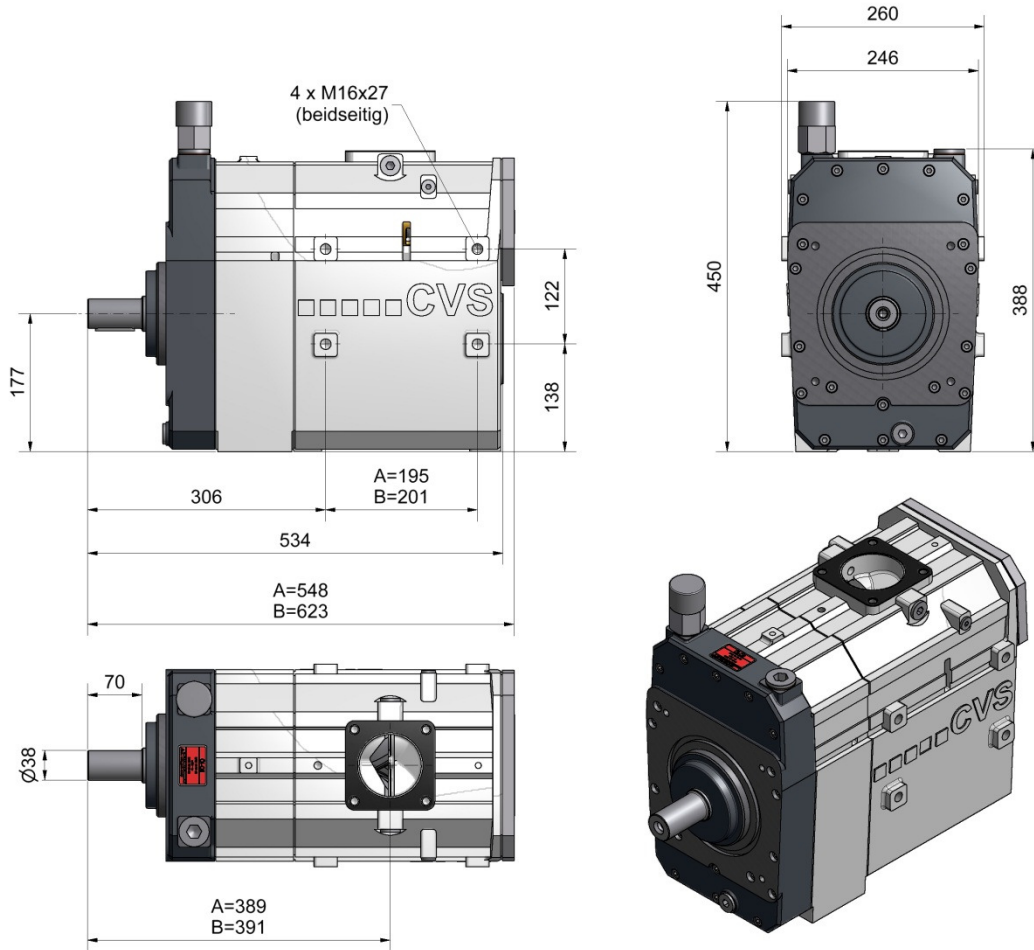

A = SKL 700
B = SKL 1100

Technical data

		SKL 700			SKL 1100			
		2400	3000	3600	2000	2400	3000	3600
Speed	rpm							
Volume flow at free air	m³/h	420	540	650	550	675	850	1050
Volume flow at 2 bar g	m³/h	385	485	600	490	600	775	980
Max. pressure	bar	2.5	2.5	2.5	2.5	2.5	2.5	2.5
Speed range	1/min	2400 – 3600			2000 – 3600			
Power requirement at 2 bar	kW	22.5	28.0	33.5	29.0	33.4	43.5	52.5
Weight	kg	113			126			

Technical subject to alteration